

**Progetto
valorizzazione del patrimonio rurale: "Latteria
Val Morel" e "Malga Pianezze".**

C.F. Comune di Limana - Fg. 32 part. 172 "Latteria Val Morel"
C.F. Comune di Limana - Fg. 35 part. 22 "Malga Pianezze"

**Latteria Val Morel
Inquadramento territoriale
Piante (stato di fatto e di progetto)
Sezioni (stato di fatto e di progetto)
Prospetti (stato di fatto e di progetto)
Opere tipo**



Comune di Limana (BL)

Il Progettista
dott.agr. Lodovico De Cesero

Studio tecnico De Cesero
Belluno - Via Cavarzano, 10/A - 0437932324

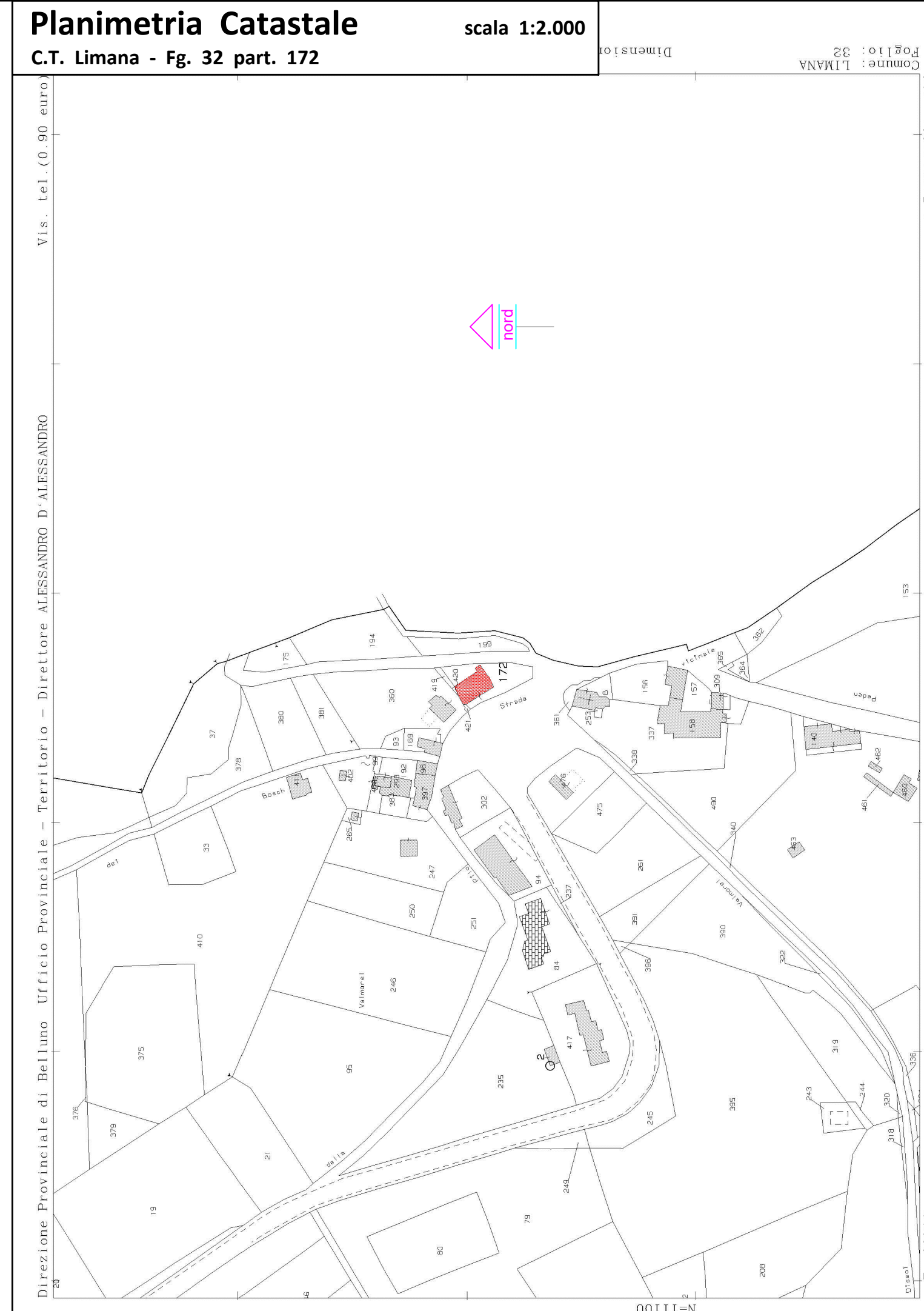
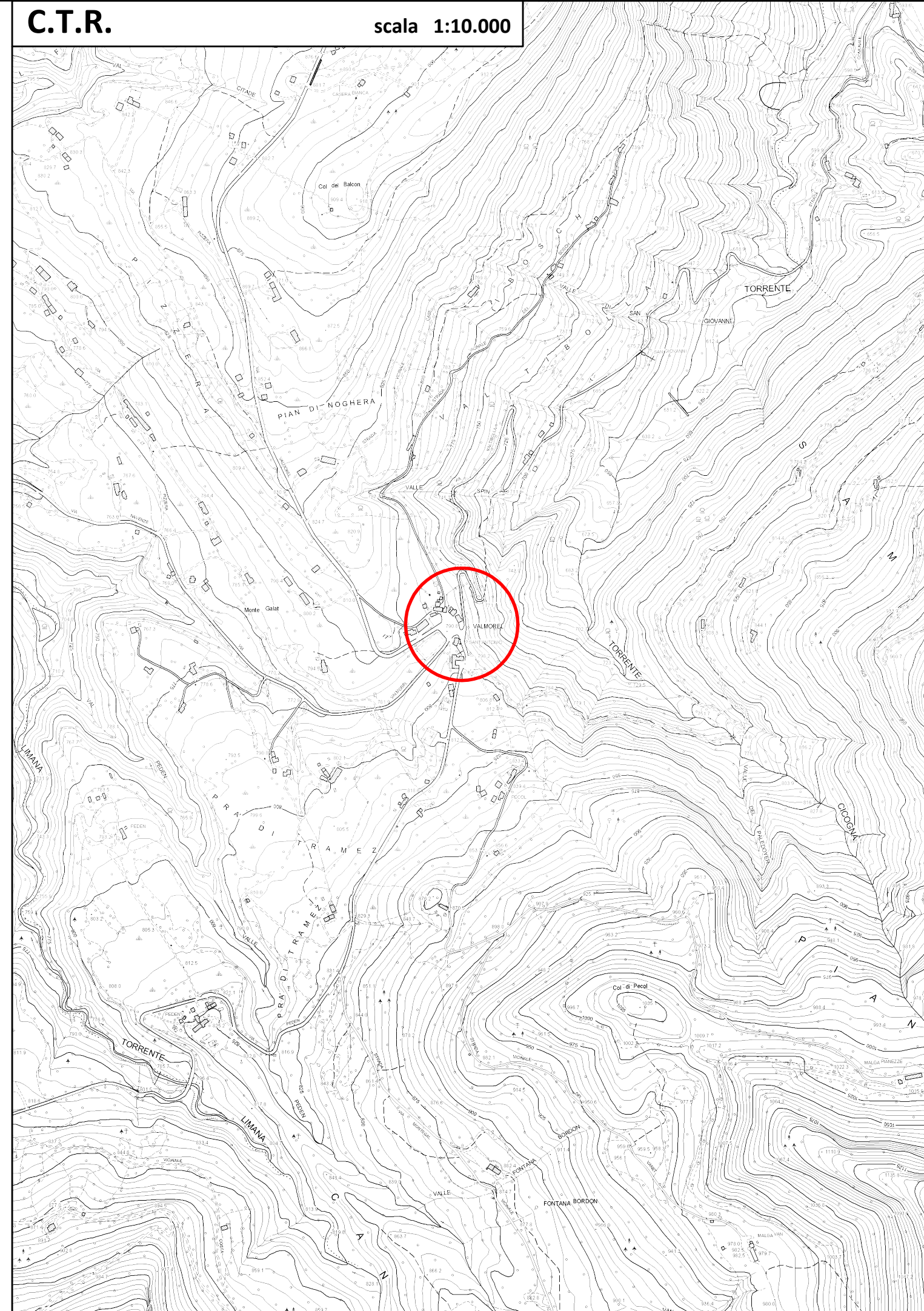
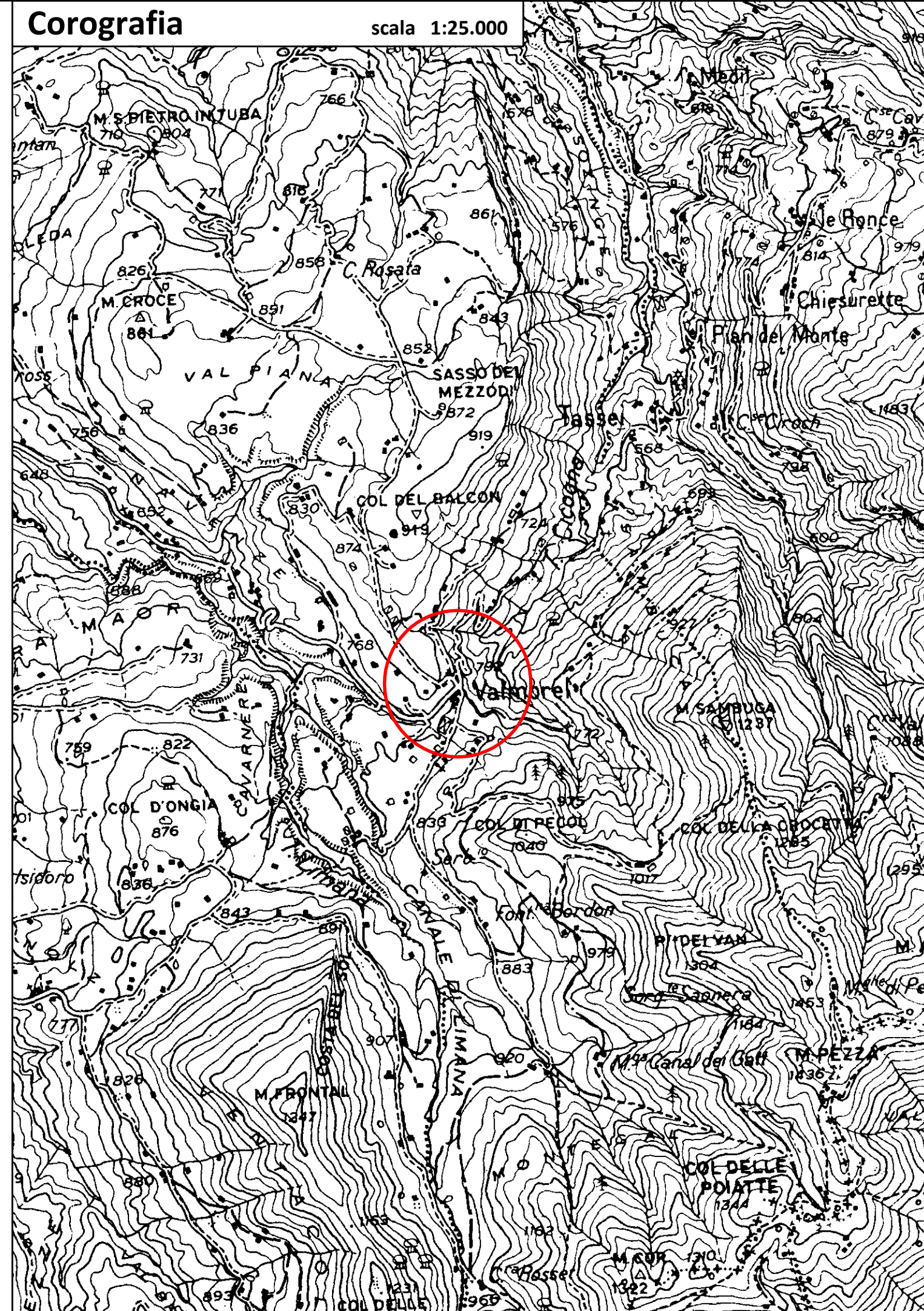

Pianta Piano Seminterrato
Stato di fatto
Scala 1:100

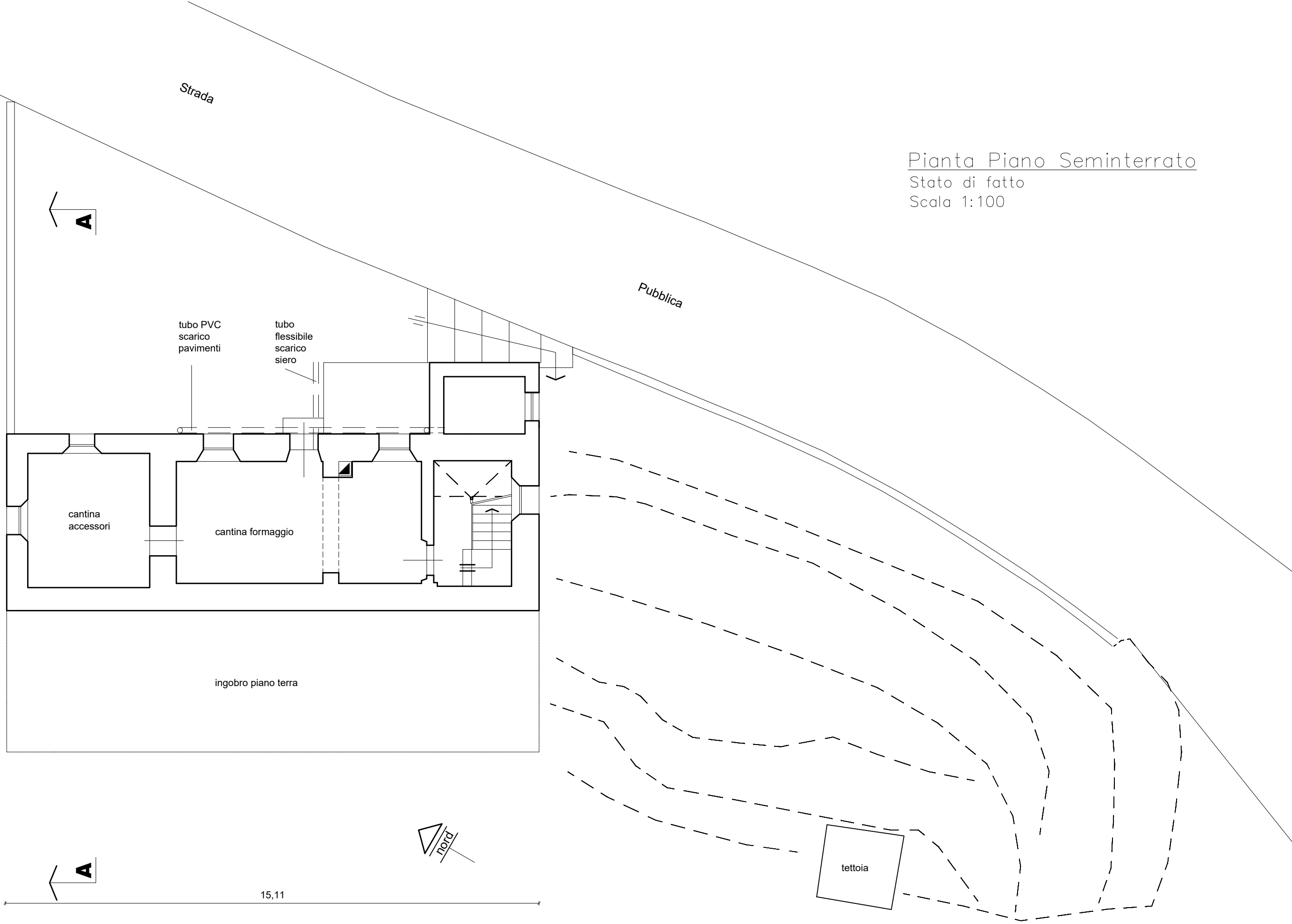

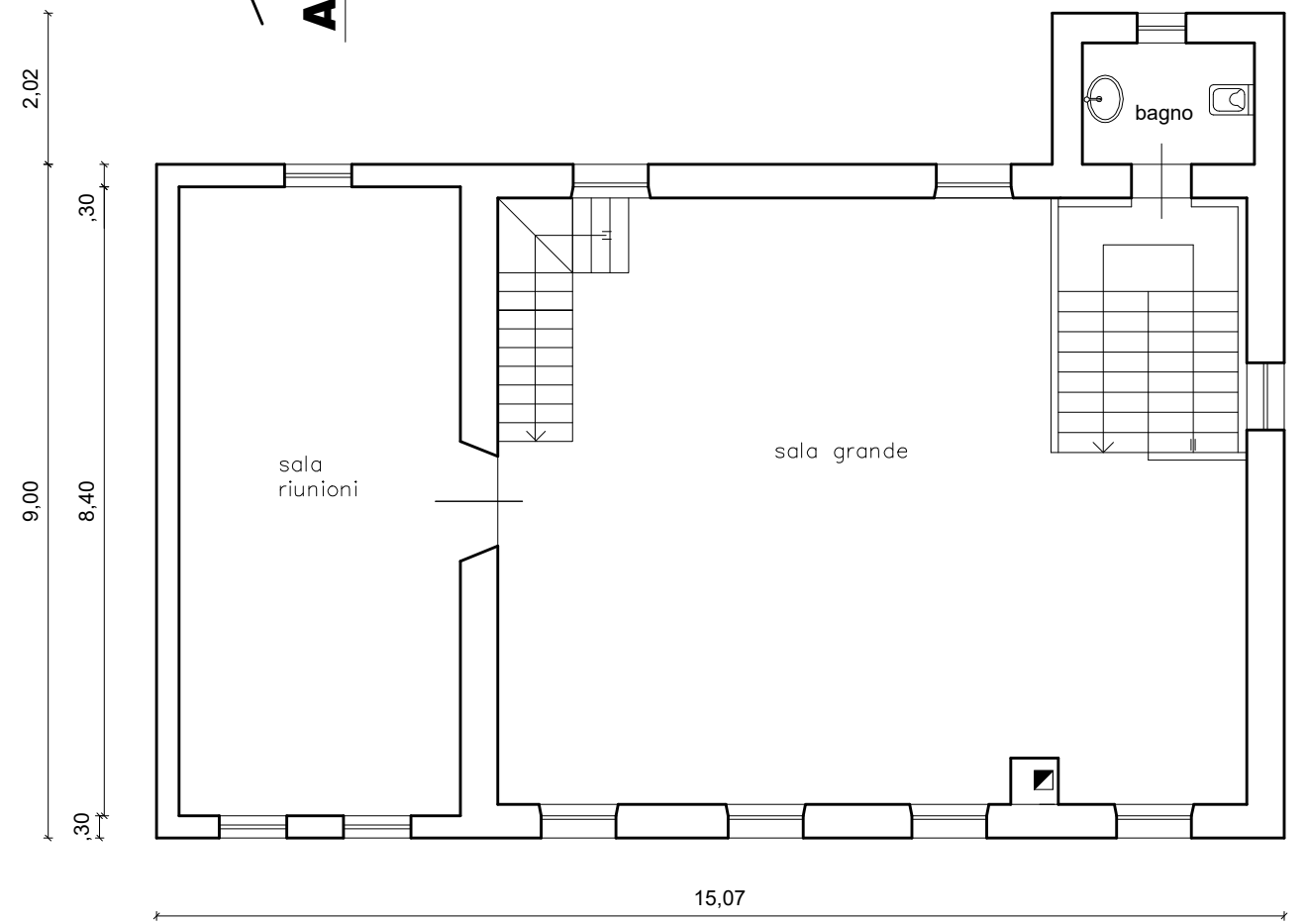
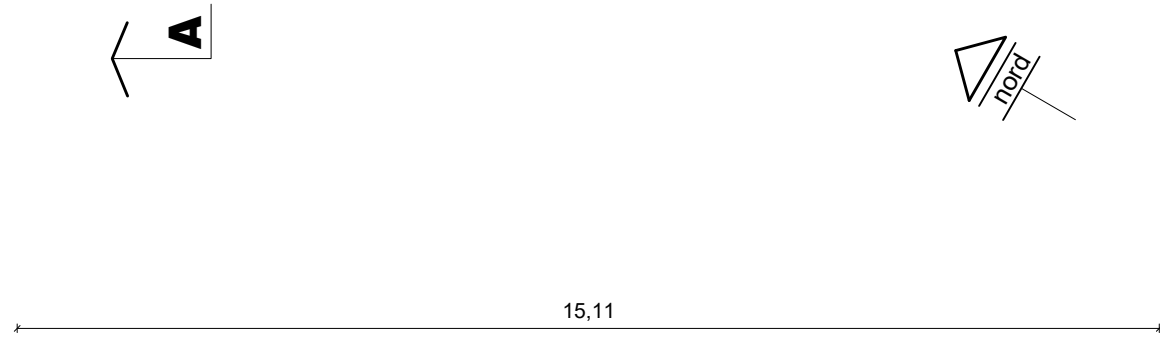
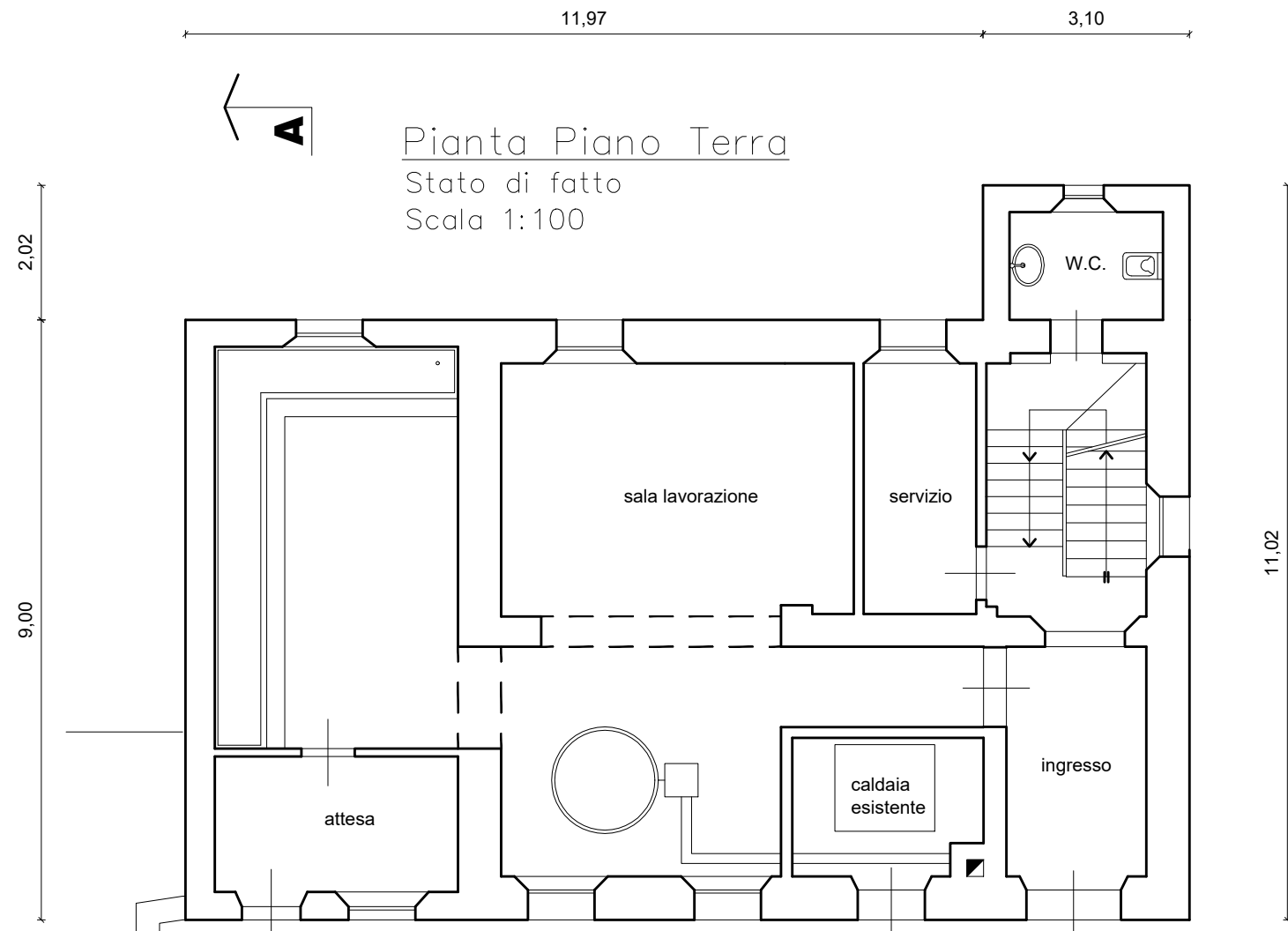

A

Prospetto Sud ovest

Stato di fatto

Scala 1:100

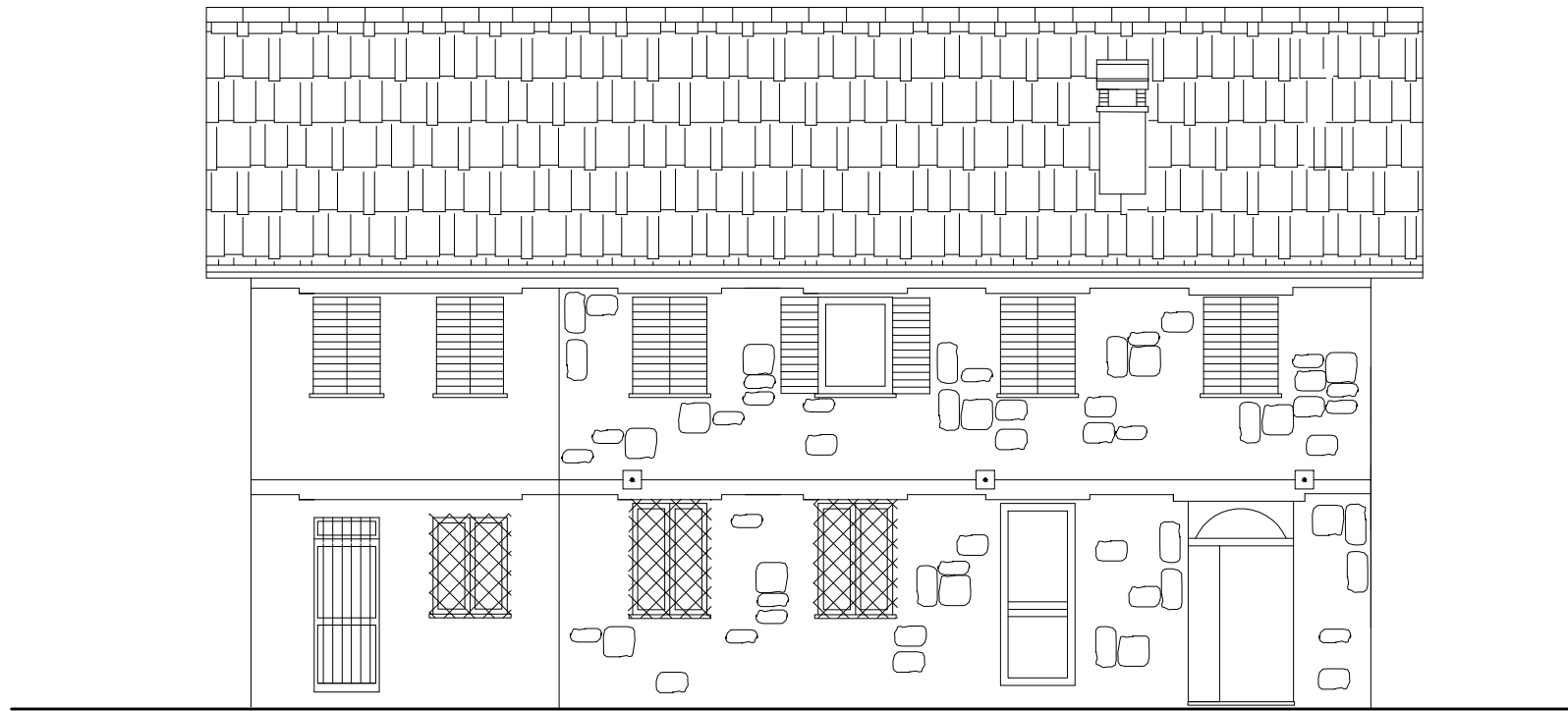

Sezione A A

Stato di fatto

Scala 1:100

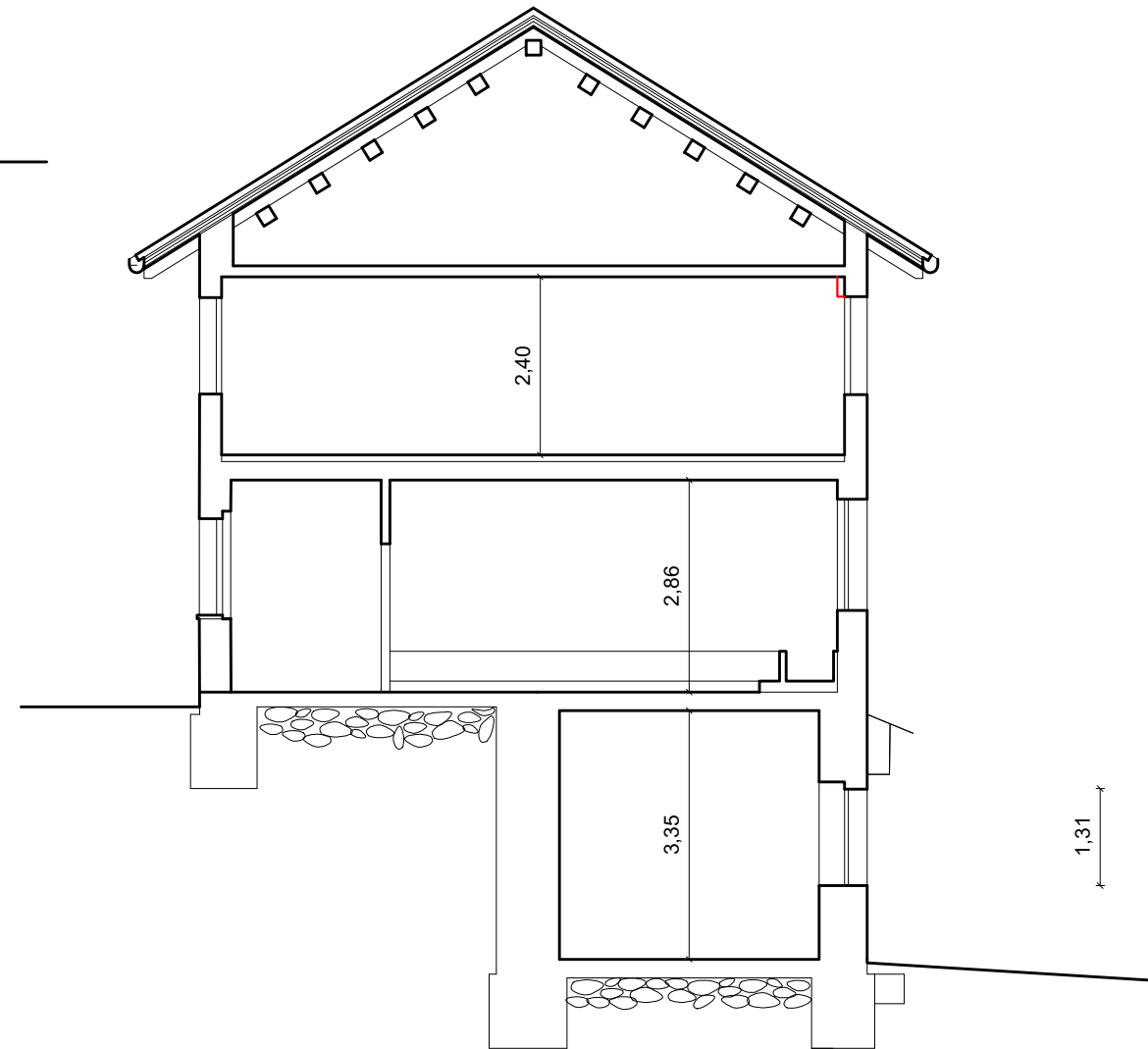

Prospetto Nord ovest

Stato di fatto

Scala 1:100

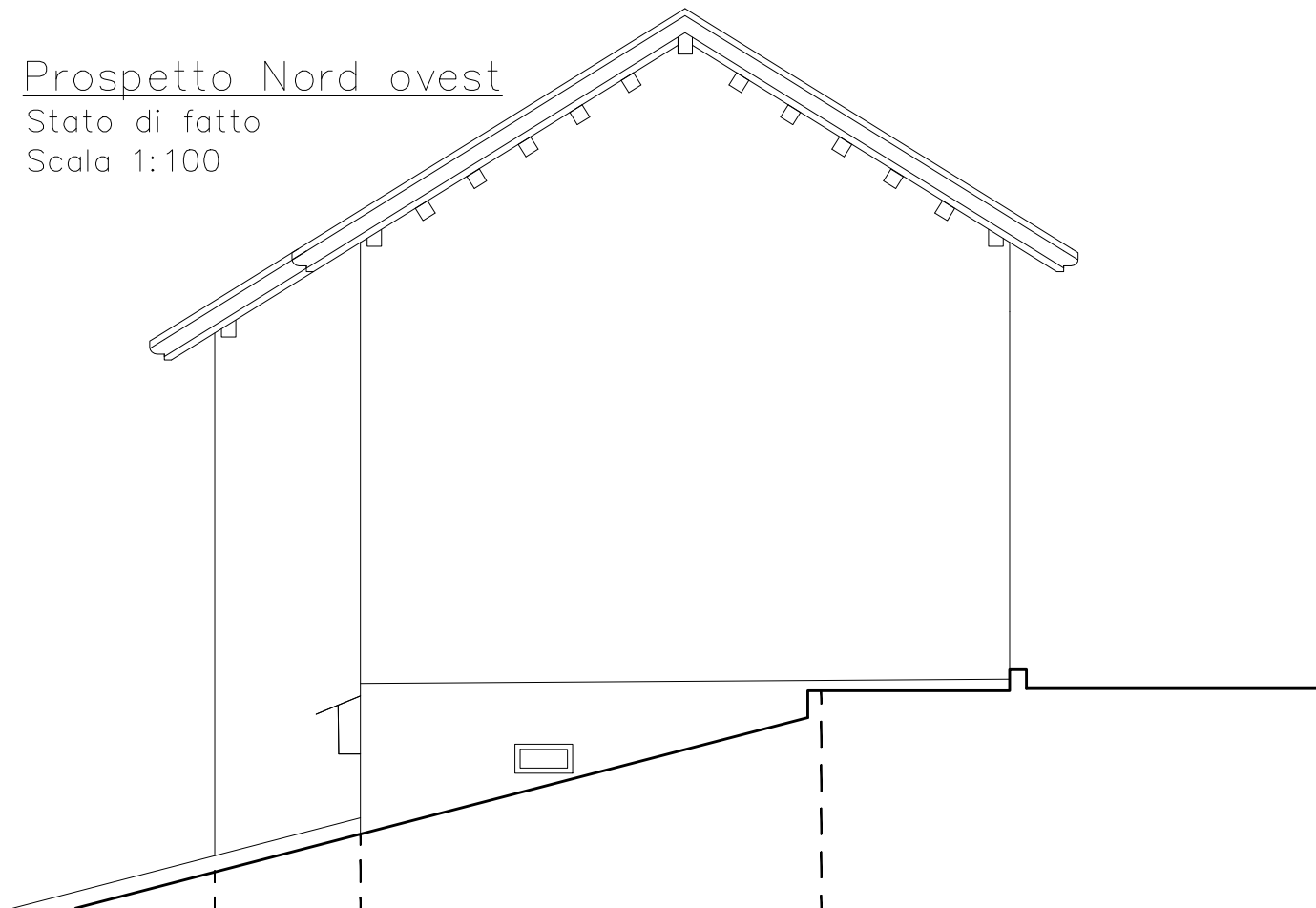

Prospetto Nord est
Stato di fatto
Scala 1:100



Prospetto Sud est
Stato di fatto
Scala 1:100

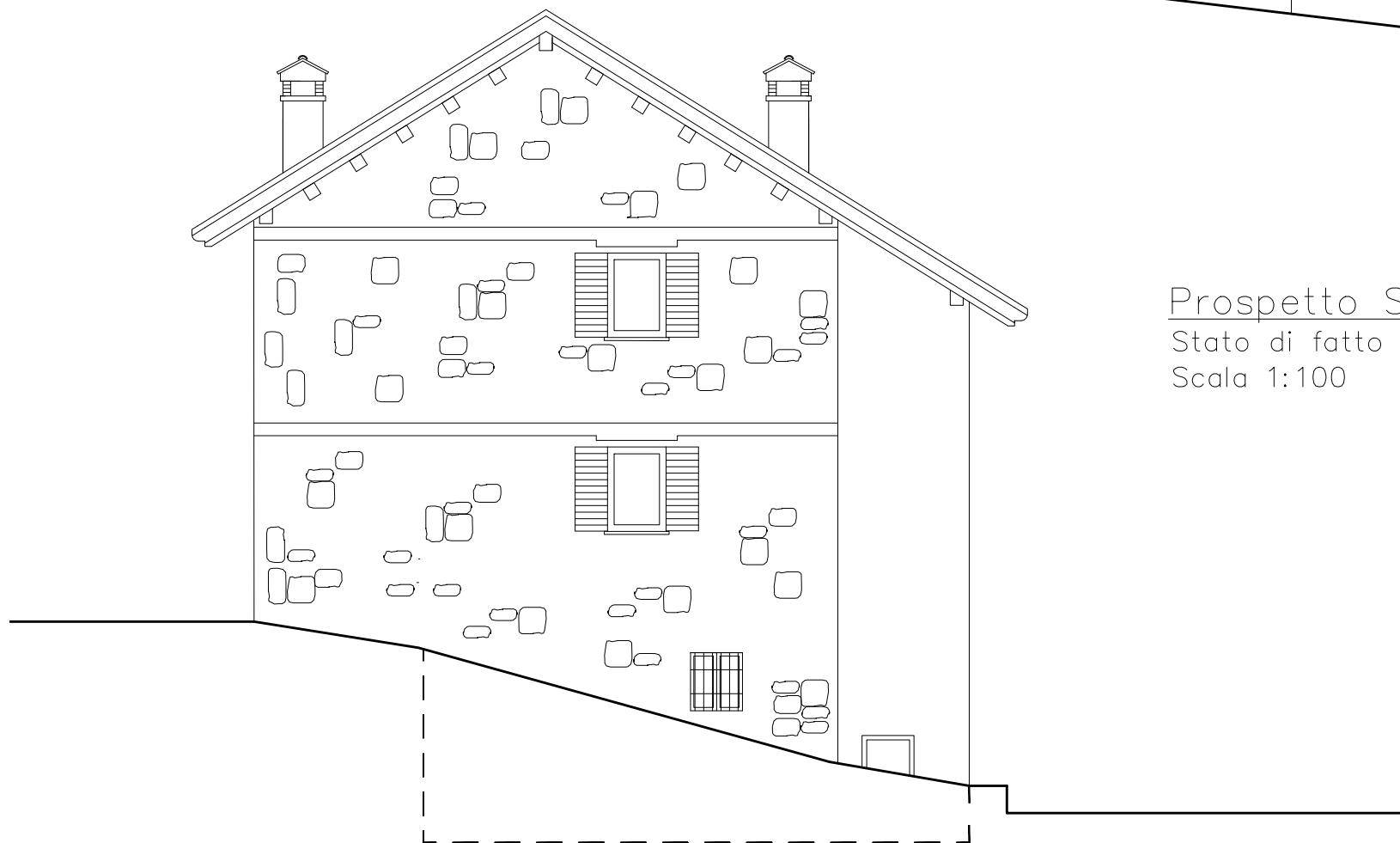

Pianta Piano Seminterrato
Stato di progetto
Scala 1:100

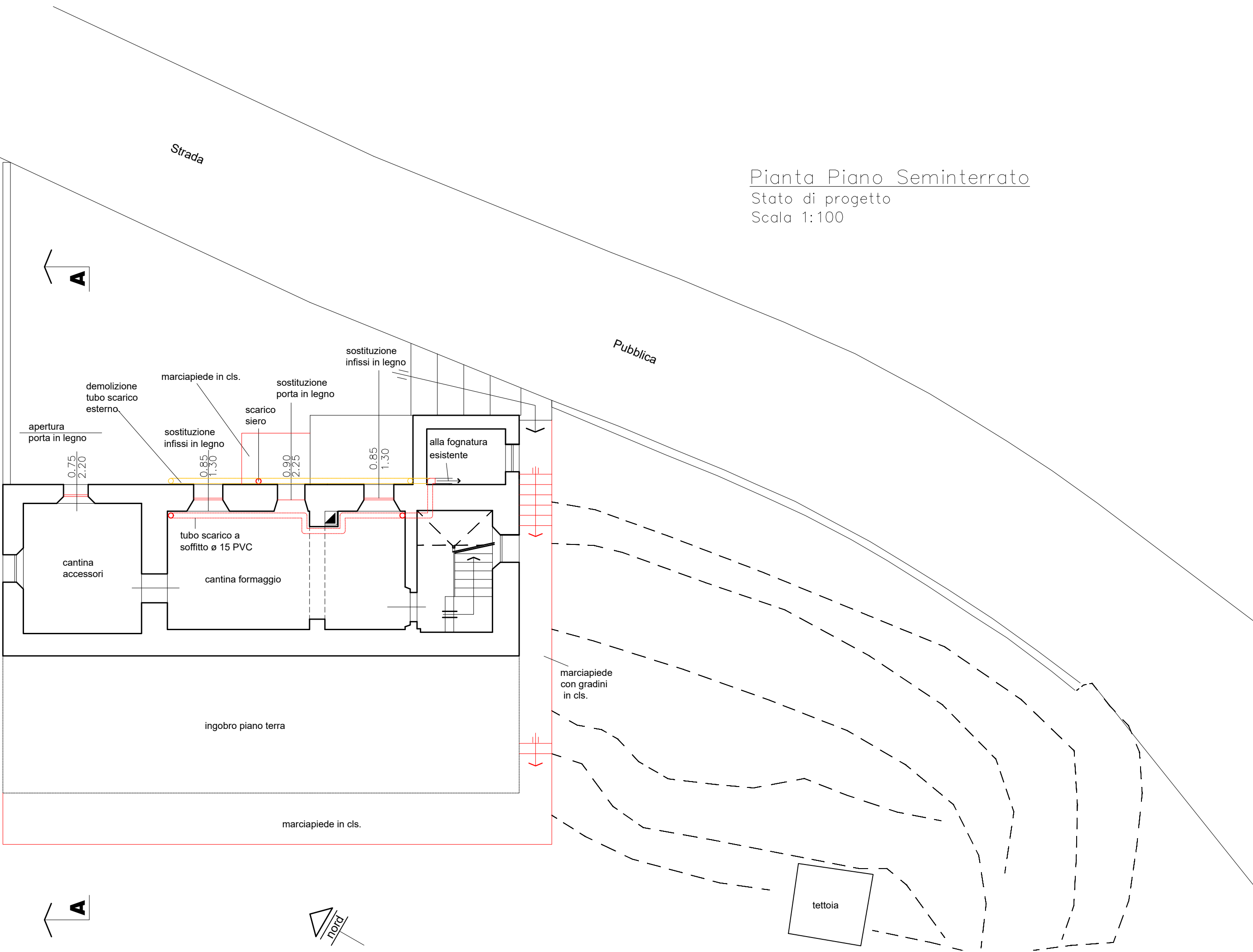

A

A

nord

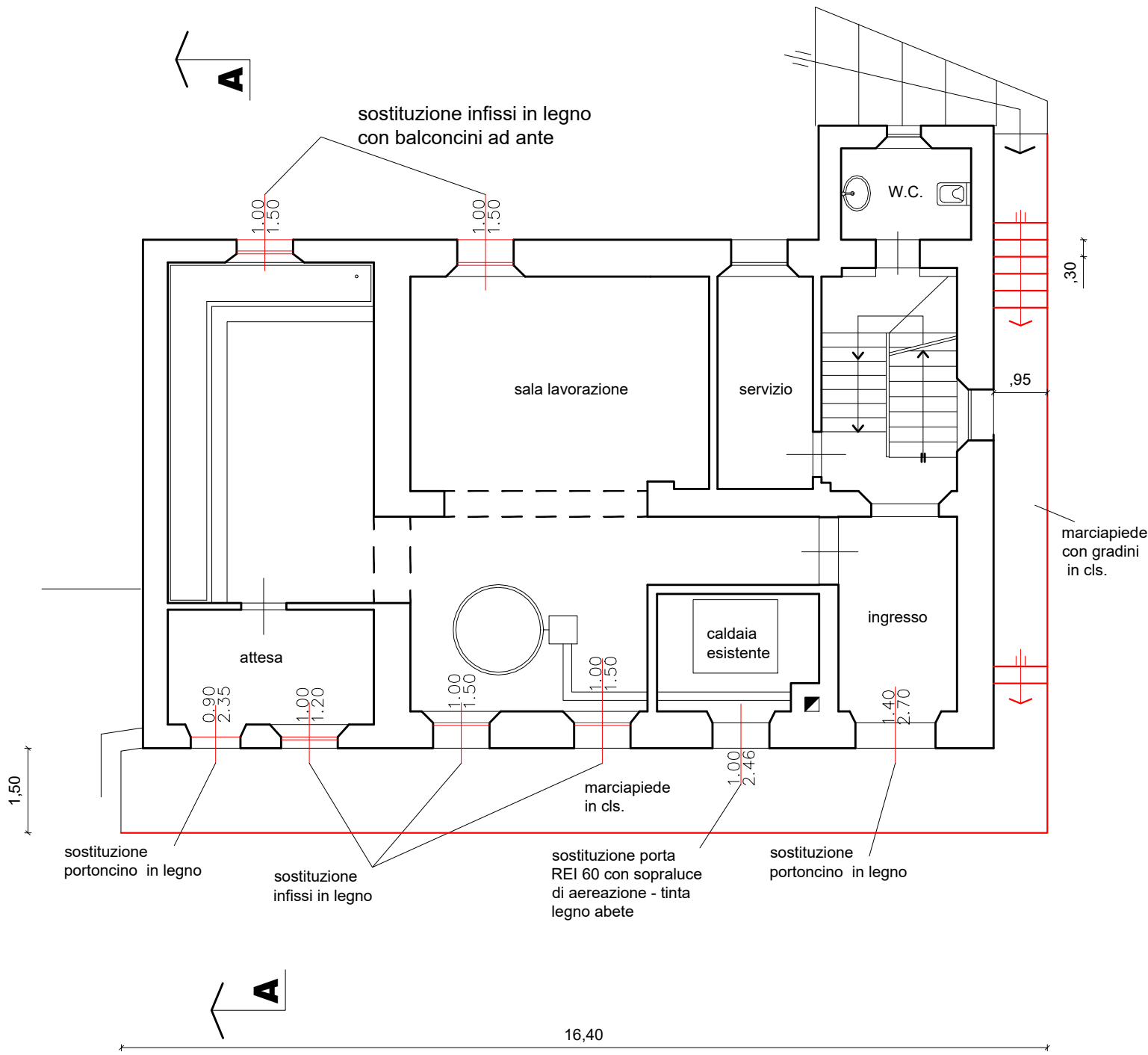

Pianta Piano Terra
Stato di progetto
Scala 1:100

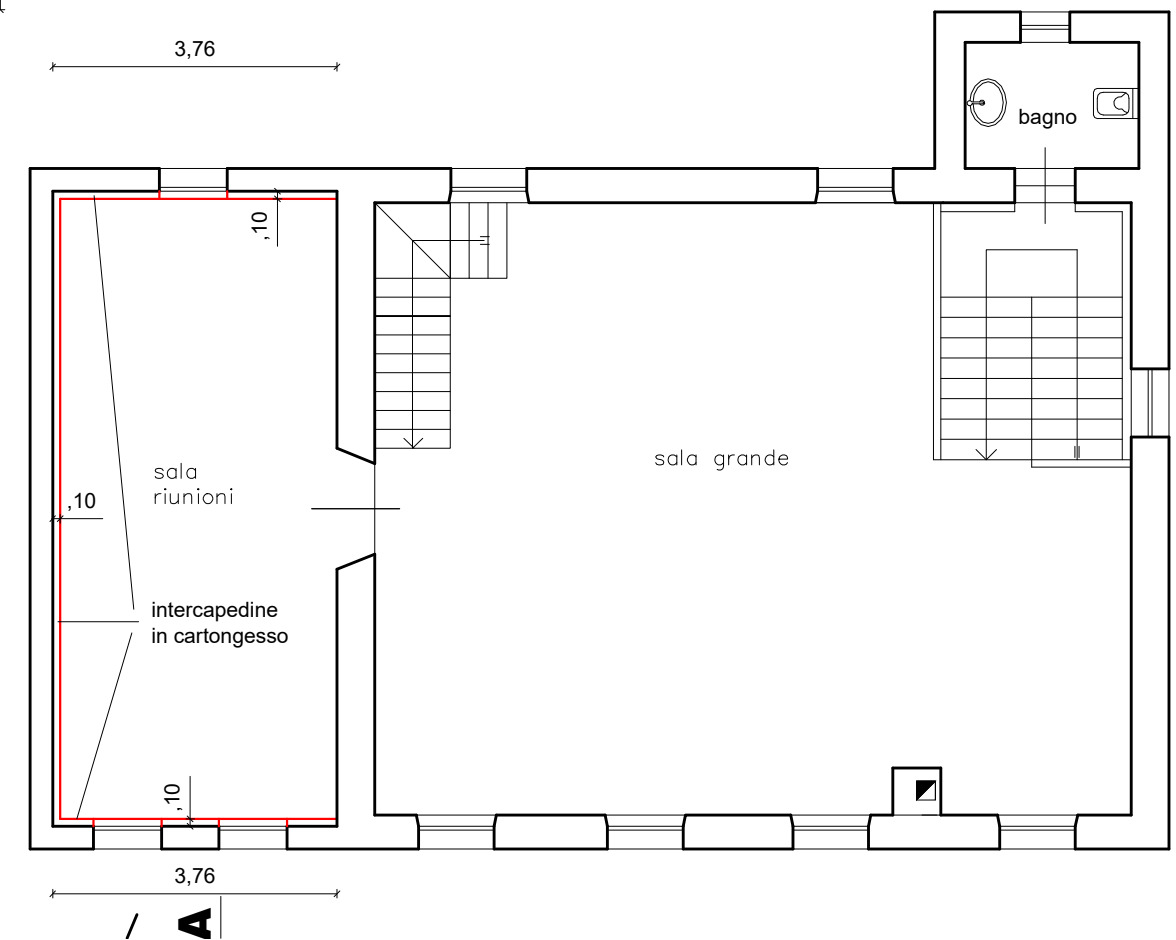
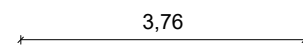

Pianta Piano Primo
Stato di progetto
Scala 1:100

Prospetto Sud ovest

Stato di progetto

Scala 1:100

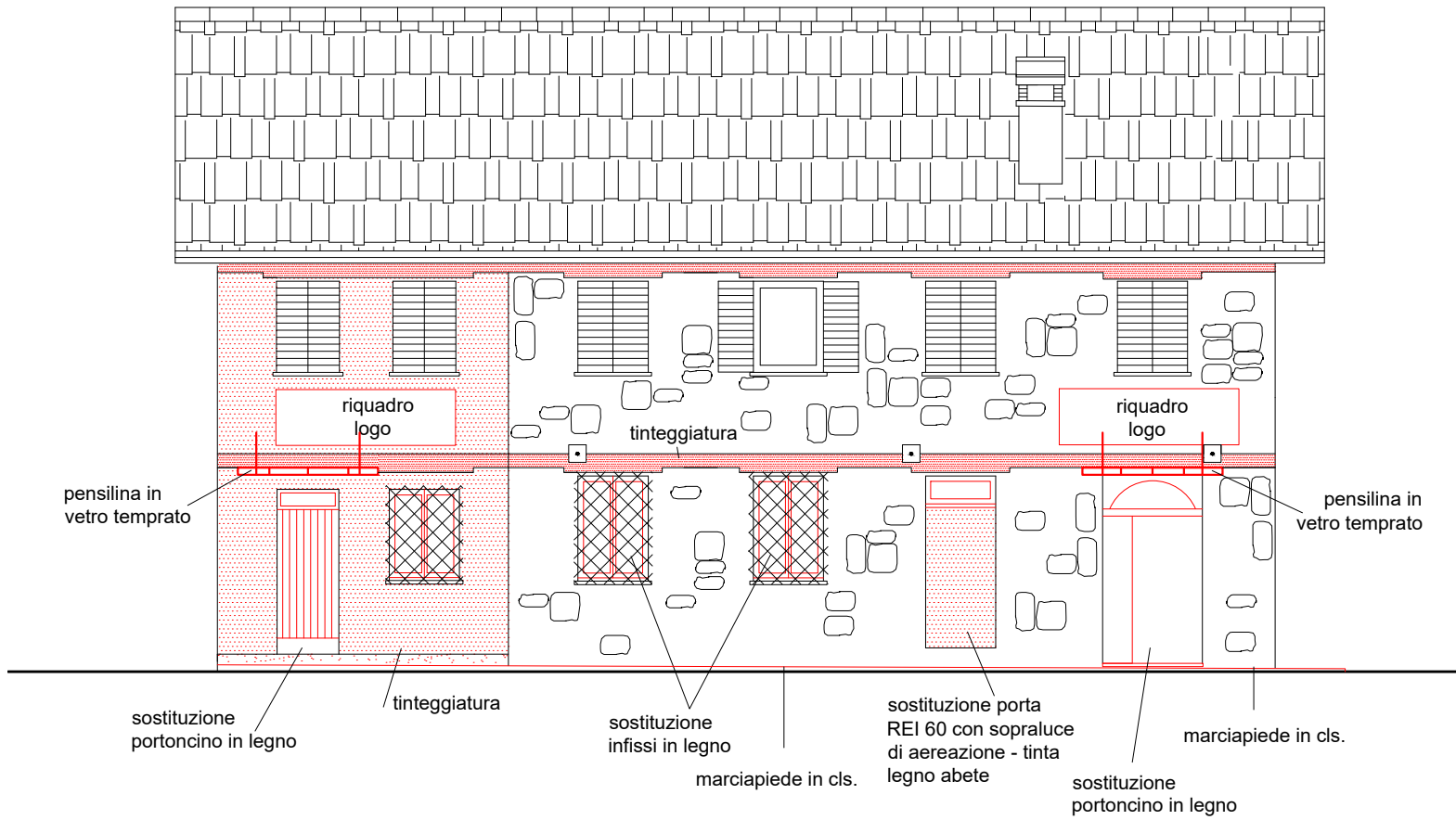

Prospetto Nord ovest

Stato di progetto

Scala 1:100

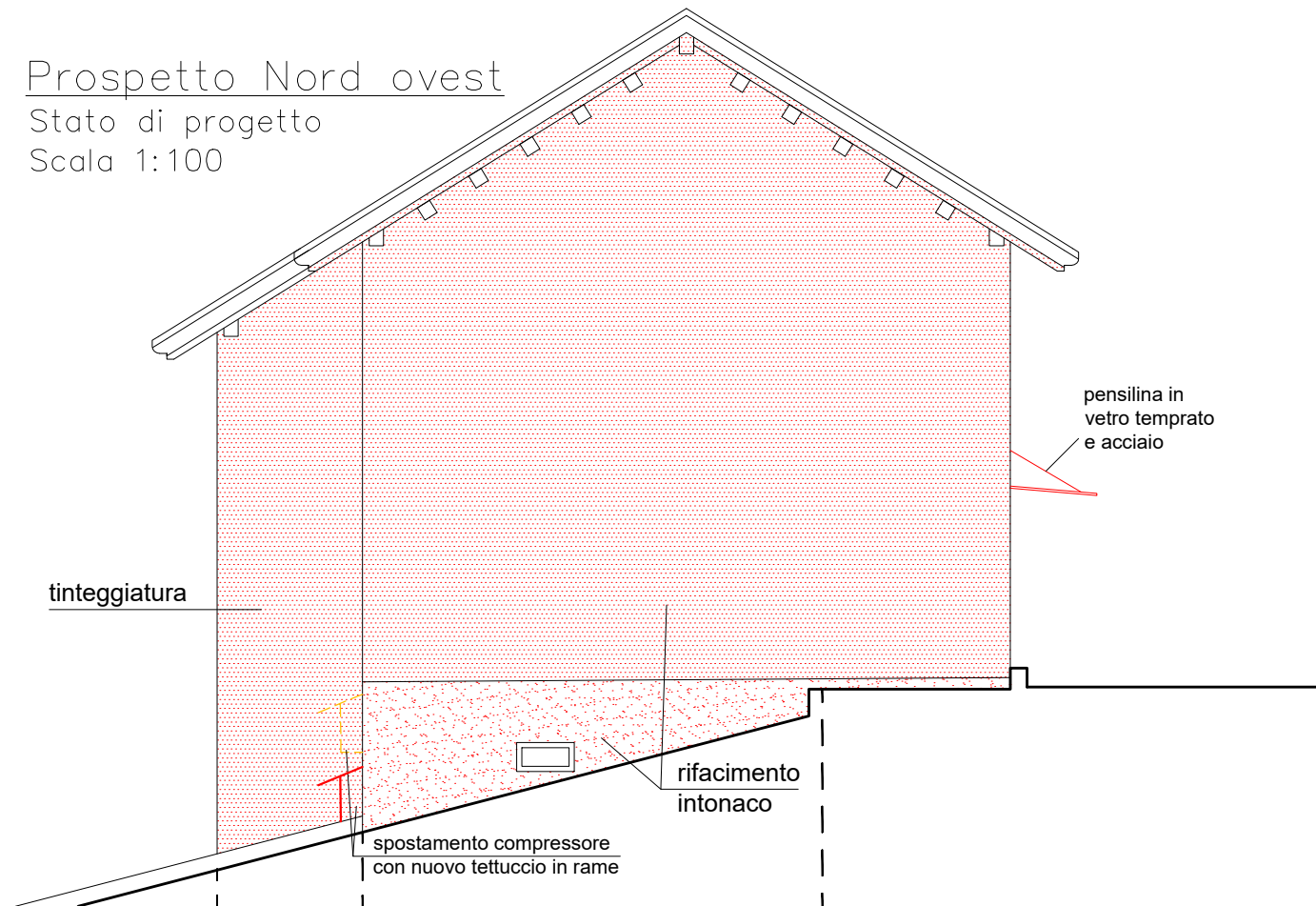

Sezione A A

Stato di progetto

Scala 1:100

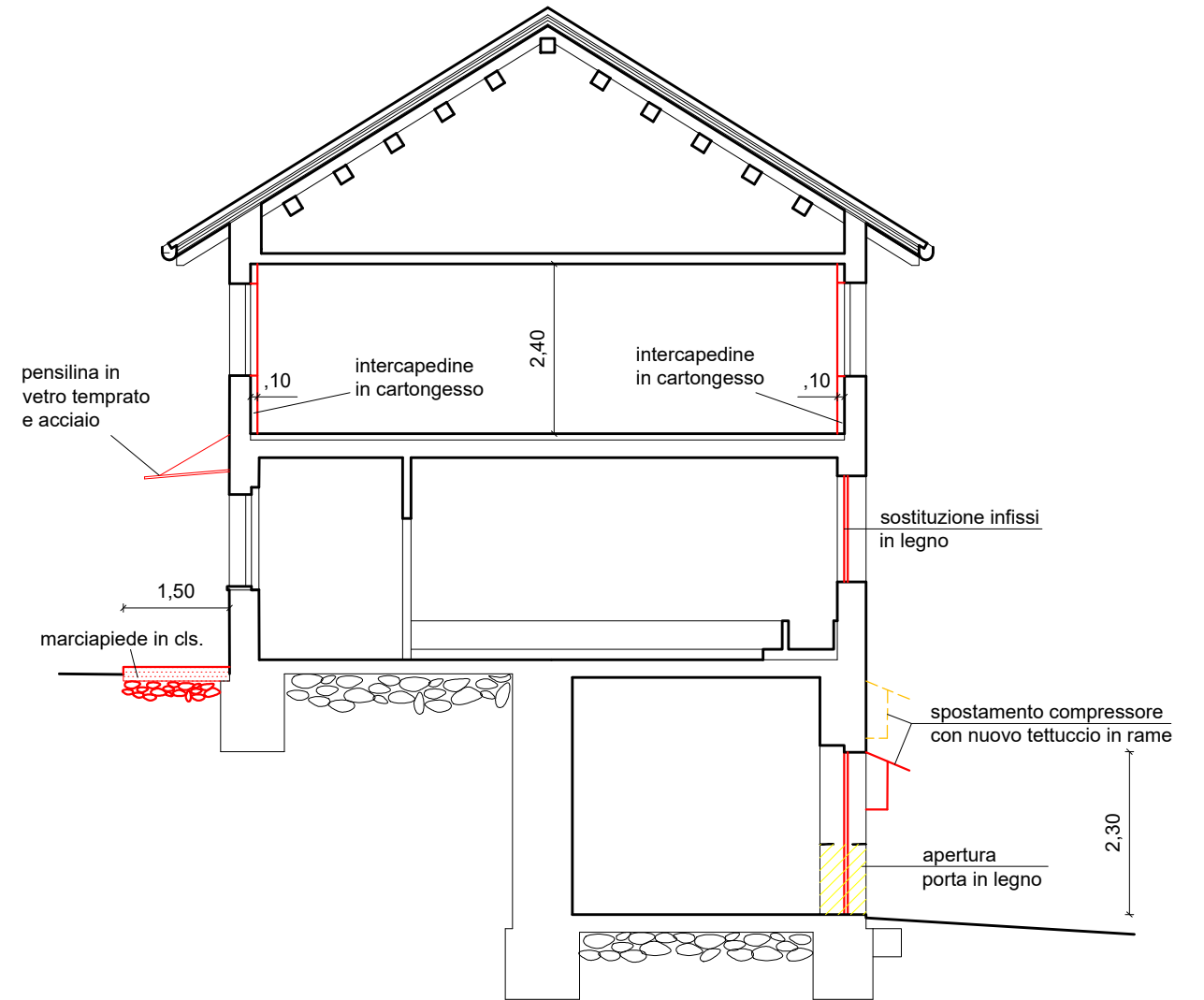

Prospetto Nord est
Stato di progetto
Scala 1:100

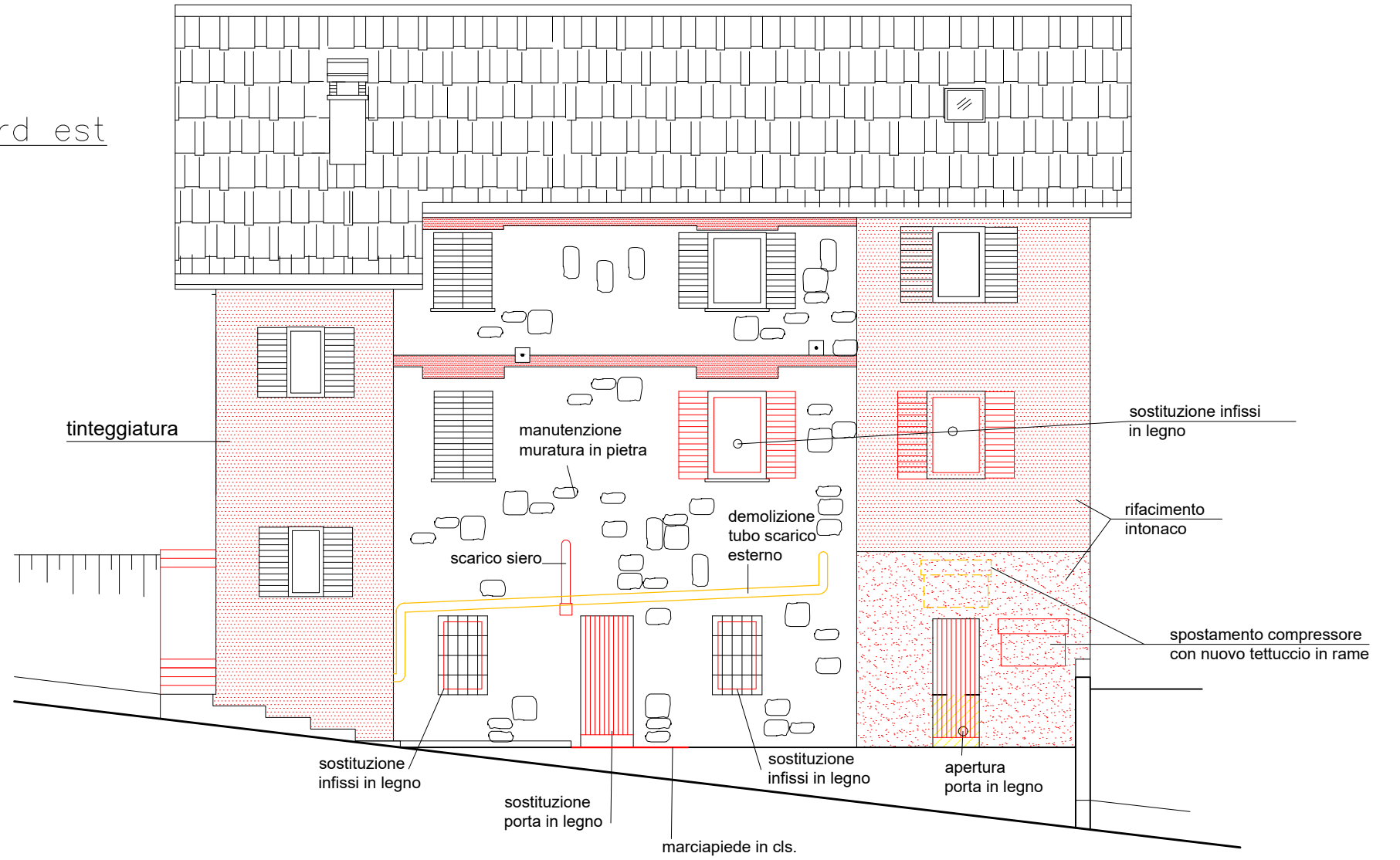

Prospetto Sud est
Stato di progetto
Scala 1:100

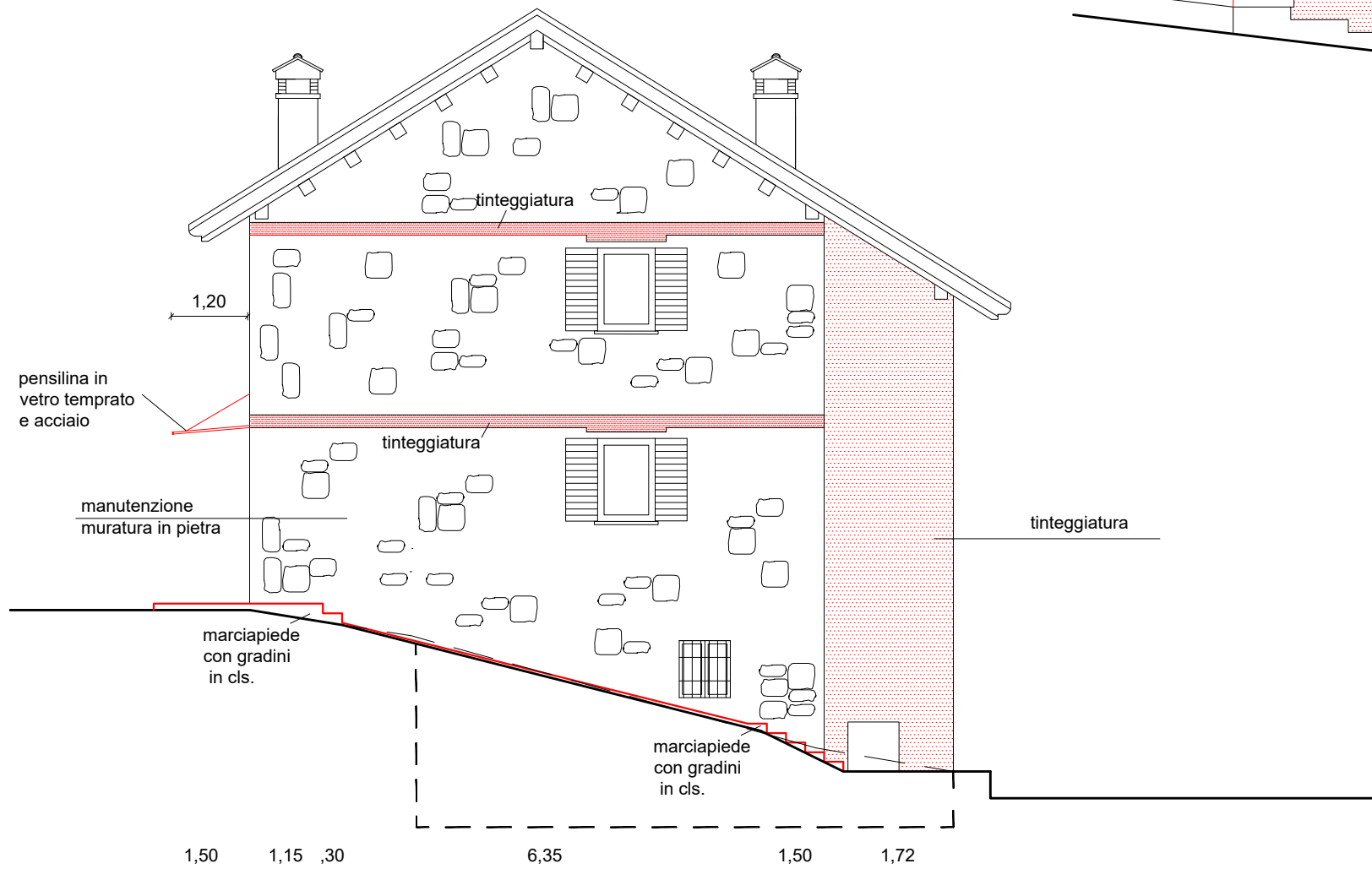

Pensiline in vetro temperato e acciaio

Pensilina tipo



dimensioni

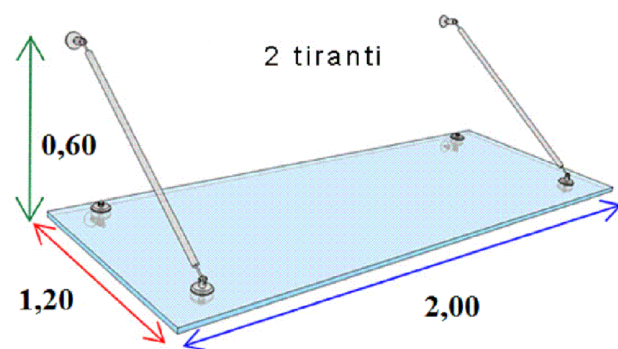

accessori

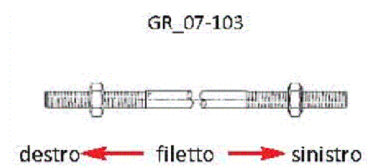
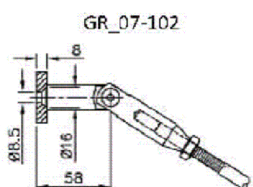
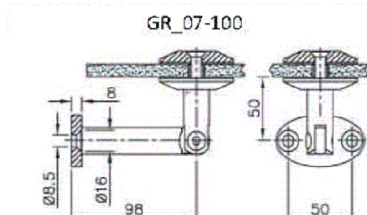
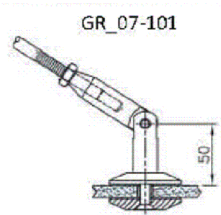

Muratura ad intercapedine con isolamento dall'interno.
(sala riunioni)

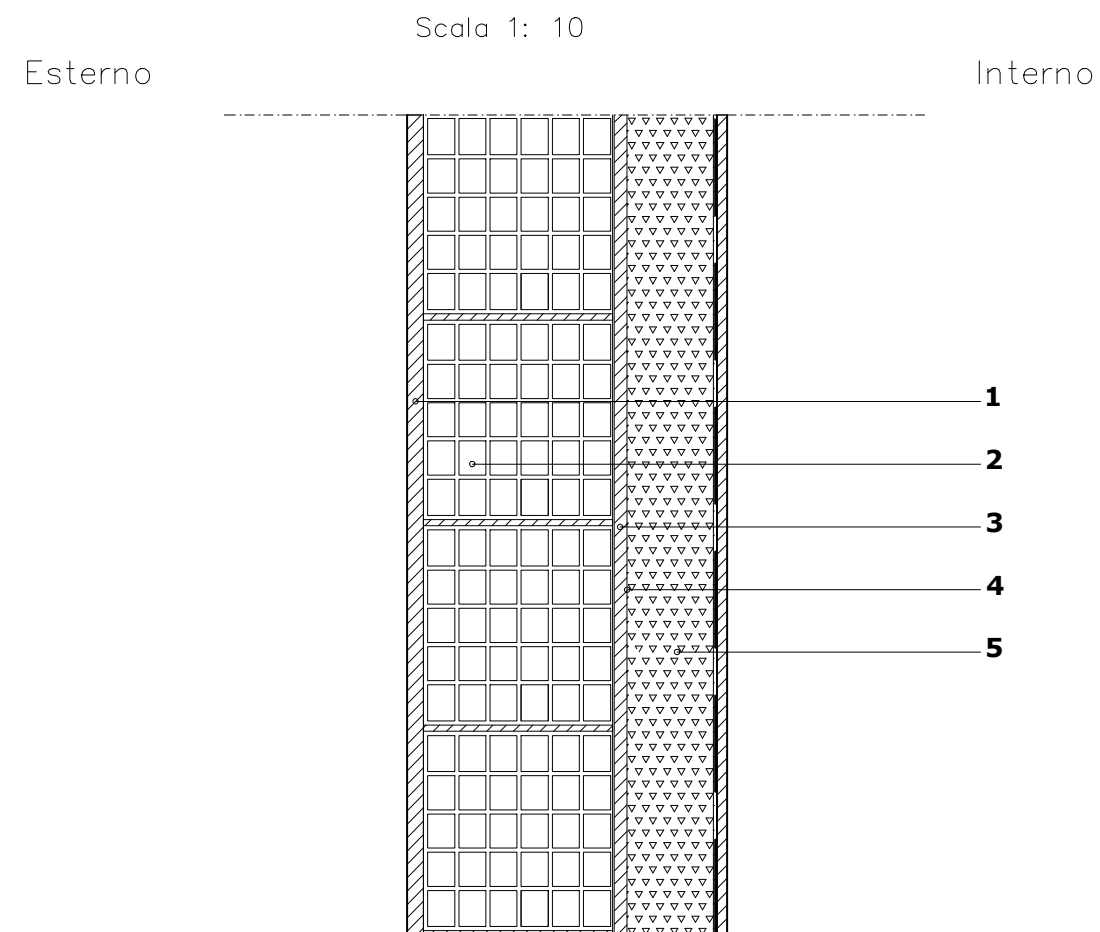

1. Intonaco sp. 20 mm
2. Blocchi in laterizio forato sp. 250 mm
3. Intonaco sp. 15 mm
4. Imprimitura
5. Pannello preaccoppiato con lastra in gesso e finitura superficiale mm100

PARTICOLARI

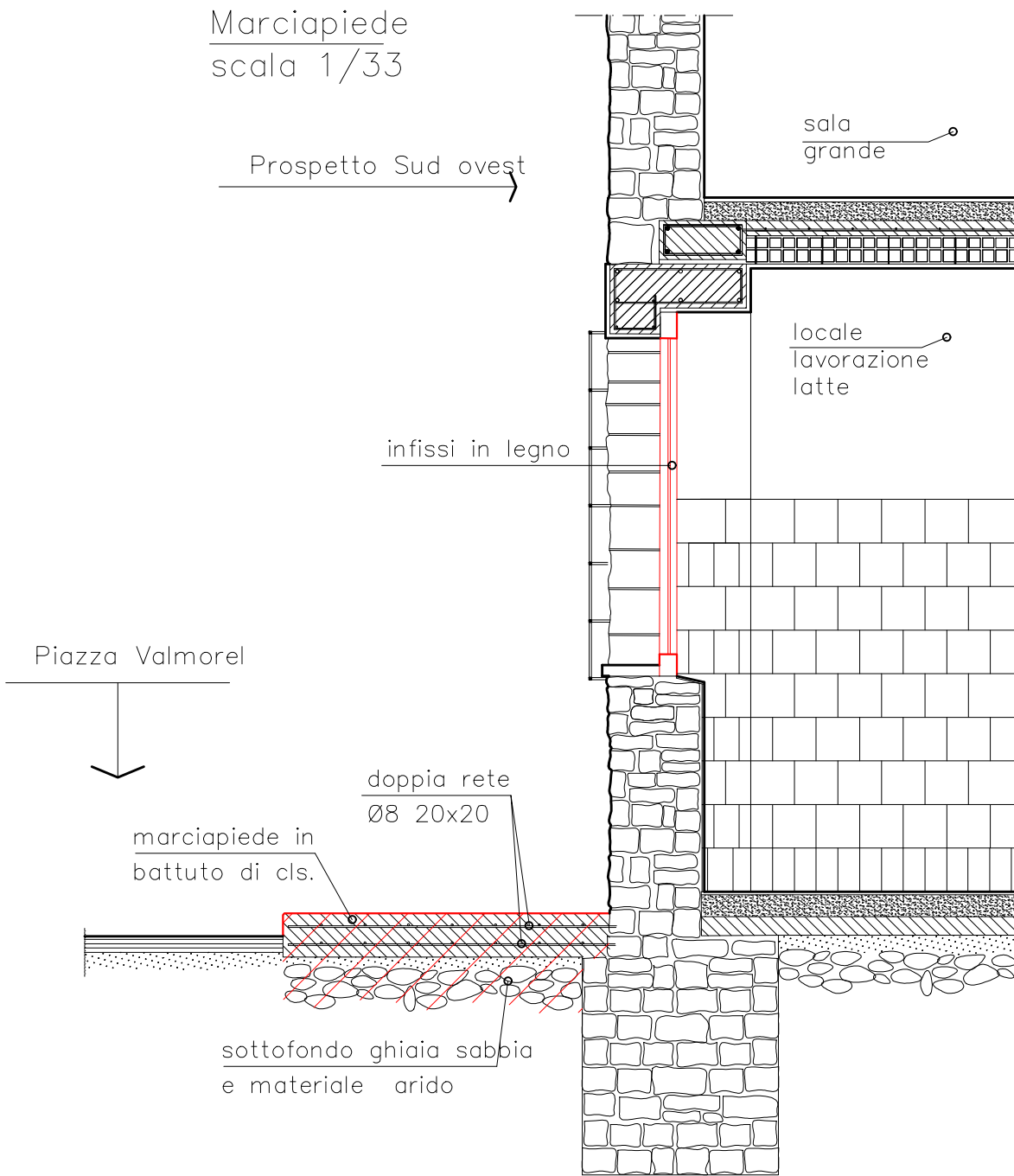

PARTICOLARI

Finestre Tipo prospetto a Nord est
Piano terra



Finestre Tipo interno prospetto
a Sud Ovest Piano terra

Finestre Tipo interno
prospetto
a Sud Ovest Piano
Seminterrato

